

I/PAC

Integrated Process Air Control

Field rugged, quick mount I/P - airset assemblies

Explosion-proof field mounted I/P transducers from ControlAir are now offered as an integrated package that comes pre-assembled with a filter regulator and pressure gauge. Users can choose from different versions of either the Type-950XP or Type-595XP I/P combined with the Type-330 filter regulator. The package is bracketed to mount on a 2" pipe as well as directly onto valve yokes or other devices that utilize 2.25" bolt spacing. Integrated units carry all agency hazardous area approvals from FM, CSA and ATEX.

Features

- **Seamless Replacements**
For existing automated control valves in the field
- **Convenient Bracketing**
Allows direct or 2" pipe mounting
- **Preassembled**
Units come preassembled with filter regulator and pressure gauge
- **Explosion-proof and Intrinsically Safe**
Approvals from FM, CSA and ATEX
- **Vibration and Position Insensitive**
- **Compact Design**
Installs where others won't



DIMENSIONS ^{IN}_[MM]

Type 950XP/Type 330 Combination

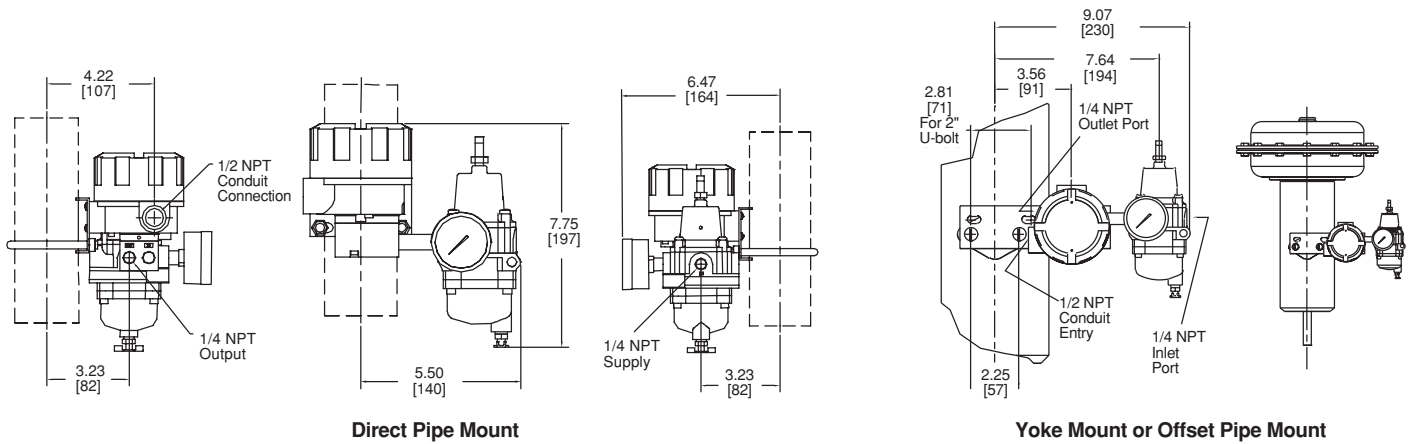

Type 595XP/Type 330 Combination

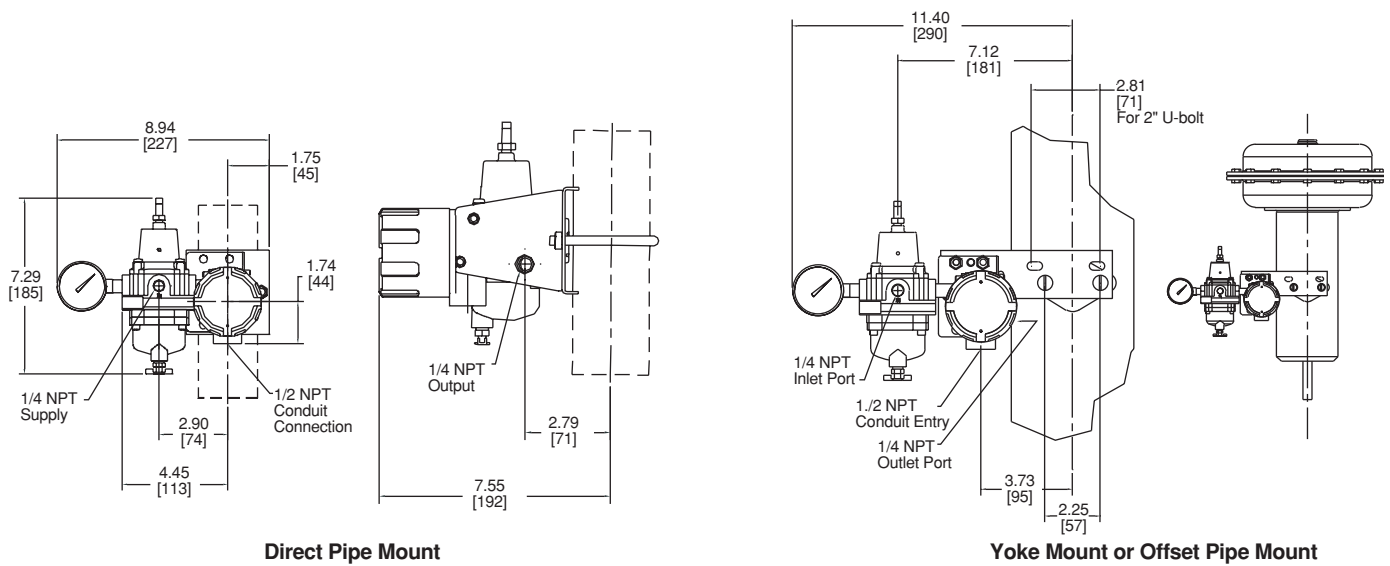



FUNCTIONAL SPECIFICATIONS

Type 950XP/Type 330 Combination

Type 595XP/Type 330 Combination

Input	4-20 MA	
Outputs	3-15 psig 3-27 psig 6-30 psig	0.20-1.0 BAR 0.20-1.8 BAR 0.40-2.0 BAR
Air Consumption	3.0 scfm (0.11 m3/hr) at mid range	0.1 scfm (0.17m3/hr)
Supply Pressure Note: Supply pressure must be a minimum of 5 psig (0.3 BAR) above maximum output	100 psig (7.0 BAR) max	3-15: 22 psig (1.5 BAR) max 3-27, 6-30: 42 psig (2.8 BAR) max
Flow Capacity	4.5 scfm (7.6 m3/hr) at 25 psig (1.7 BAR) supply 12.0 scfm (20.0 m3/hr) at 100 psig (7.0 BAR) supply	2.4 scfm (4.1 m3/hr)max.
Temperature Limits	-40°F to +160°F (-40°C to +71°C)	-67°F to +185°F (-55°C to +85°C)
Relative Humidity	75% average - 95% short time non-condensing	
Loop Load	10 Volts @ 20mA	5.2 Volts @ 70°F

PERFORMANCE SPECIFICATIONS

Linearity (Independent)	0.10 % of span (± 0.25 with field-selectable option)	$< \pm 0.5\%$ of span
Hysteresis	0.10 % of span (± 0.25 with field-selectable option)	$< \pm 0.5\%$ of span
Deadband	$< \pm 0.02\%$ of span	$< \pm 0.1\%$ of span
Repeatability	$< \pm 0.10\%$ of span (± 0.25 with field-selectable option)	$< \pm 0.3\%$ of span; $< \pm 0.15\%$ of span typical
Mounting Orientation Effect	No measurable effect	$< \pm 0.5\%$ / 90 degree change
Air Supply Sensitivity	No measurable effect	$< .3\%$ / 1.5 (0.10 BAR) psig change
Vibration Effect	Less than $\pm 1.0\%$ of span under the following conditions: 5-15Hz @ 0.8 inches constant displacement; 15-500Hz @ 10g's	$< \pm 1\%$ up to 10g and 20-80 Hz
Temperature Effect	$\pm 0.045\%/^{\circ}\text{F}$ (0.07%/°C) of span	$< \pm 0.75\%$ / 10°F (5.6°C) change

PHYSICAL SPECIFICATIONS

Housing	NEMA 4X (IP 65)	
I/P Port Sizes	Pneumatic: 1/4" NPT Electric: 1/2" NPT, M20-1.5 (ATEX)	
Media	Clean, dry, oil-free, instrument air, filtered to 40 micron	
Electrical Connections	Terminal block	
Materials	Housing: Chromate-treated aluminum with epoxy paint. NEMA 4X (IP65) Elastomers: Buna-N Trim: Stainless steel; brass; zinc-plated steel	
Weight	3.5 lbs (1.6 kg) 4 lbs (1.8 kg) with (E) option	3.1 lbs (1.4 kg)

Type 950XP/Type 330 Combination

Factory Mutual (FM) & Canadian Standards Association (CSA) Approval

Zone Certification	Entity Parameters	Temperature Code	Enclosure
Intrinsic Safety Class I, Division 1, Groups C & D Class II, Division 1, Groups E, F, & G Class III, Division 1; Fibers	Vmax = 30 Vdc Imax = 125 mA Pi = 0.7 W Ci = 0 nF Li = 0 mH	T4 Ta=+70°C	Nema-4X
Explosion-Proof Class I, Divisions 1 & 2, Groups B, C & D Class II & III, Division 1, Groups E, F, & G	---	T4 Ta=+70°C	Nema-4X

Suitable for use with methane or natural gas supply pressure media when ordered with tapped exhaust and factory sealed conduit assembly (Option E).

ATEX Approval

Zone Certification	Entity Parameters	Temperature Code	Enclosure
Intrinsic Safety Ⓜ II 1 G Ex ia II B	Vmax = 30 Vdc Imax = 125 mA Pi = 0.7 W Ci = 0 nF Li = 0 mH	T4 -40°C ≤ Ta ≤ 70°C	IP65
Flameproof Ⓜ II 2 G Ex d II B + H2		T4 -40°C ≤ Ta ≤ 70°C	IP65
Limited Energy Ⓜ II 3 G Ex nA nL IIC		T4 -40°C ≤ Ta ≤ 70°C	IP65

Type 595XP/Type 330 Combination

Factory Mutual (FM) & Canadian Standards Association (CSA) Approval

Zone Certification	Entity Parameters	Temperature Code	Enclosure
Intrinsic Safety Class I, Division 1, Groups A, B, C & D Class II, Division 1, Groups E, F, & G Class III, Division 1; Fibers	Vmax = 30 Vdc Imax = 150 mA Pi = 0.7 W Ci = 0 nF Li = 0 mH	T4 -40°C ≤ Ta ≤ 75°C	Nema-4X
Nonincendive Class I, Division 2, Groups A, B, C & D Class II, Division 2, Groups E, F, & G Class III, Division 2; Fibers		T4 -40°C ≤ Ta ≤ 75°C	
Explosion-Proof Class I, Divisions 1 & 2, Groups B, C & D Class II & III, Division 1, Groups E, F, & G	---	T6 -40°C ≤ Ta ≤ 75°C	Nema-4X

Suitable for use with methane or natural gas supply pressure media when ordered with tapped exhaust and factory sealed conduit assembly (Option E).

ATEX Approval

Zone Certification	Entity Parameters	Temperature Code	Enclosure
Intrinsic Safety Ⓜ II 1 G Ex ia II C	Vmax = 30 Vdc Imax = 125 mA Pi = 0.7 W Ci = 0 nF Li = 0 mH	T* -55°C to Ta Max*	IP65
Flameproof Ⓜ II 2 G Ex d II B + H2 Ⓜ II 2 D Ex tD A21 T85°C	---	T6 -40°C ≤ Ta ≤ 75°C	IP65
Limited Energy/Non-Sparking Ⓜ II 3 G Ex nL IIC Ⓜ II 3 G Ex nA nL IIC	---	T* -55°C to Ta Max* T6 -55°C ≤ Ta ≤ 85°C	IP65

*See energy limiting parameters. Refer to Instruction Manual 441-622-099.

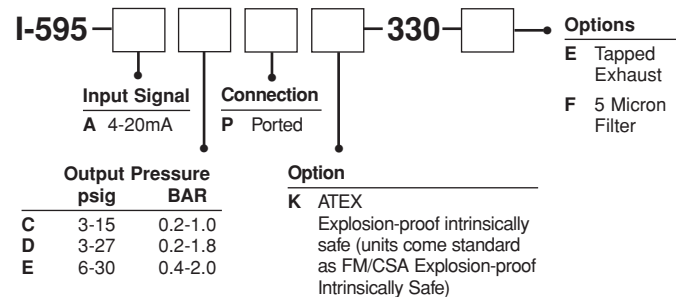
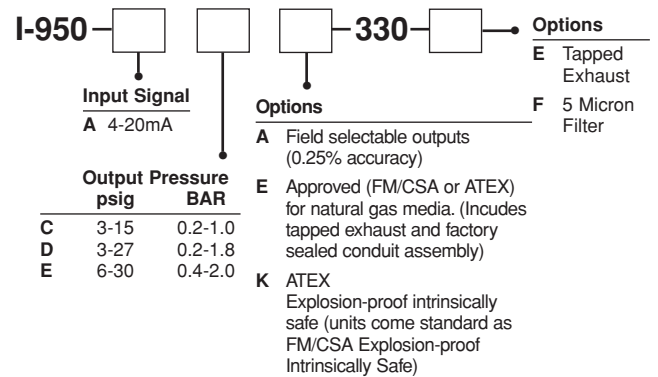

Warranty

ControlAir, Inc. products are warranted to be free from defects in materials and workmanship for a period of eighteen months from the date of sale, provided said products are used according to ControlAir, Inc. recommended usages. ControlAir, Inc.'s liability is limited to the repair, purchase price refund, or replacement in kind, at ControlAir, Inc.'s sole option, of any products proved defective. ControlAir, Inc. reserves the right to discontinue manufacture of any products or change products materials, designs or specifications without notice. Note: ControlAir does not assume responsibility for the selection, use, or maintenance of any product. Responsibility for the proper selection, use, and maintenance of any ControlAir product remains solely with the purchaser and end user.



8 Columbia Drive / Amherst, NH 03031 USA
 Website: www.controlair.com
 Email: sales@controlair.com
 603-886-9400 FAX 603-889-1844



ISO-9001:2008