

Humidity & Temperature Electronic Transmitter with replaceable “Humi-chip” module H1 line

The “H1” transmitter operates by using the value made by a highly accurate capacitive sensor that is integrated in a silicon microchip.

This new technology allows for accurate process measurements, is extremely reliable, and offers excellent long-term stability. The sensor is very durable and moisture resistant.

The “Humi-chip” module that incorporates the sensor can be easily interchanged without the need for re-calibration.

For further operator ease of use, relative humidity values can be displayed on the optional integrated LCD display, or sent via analogue outputs to other display devices.

- **Humidity and Temperature outputs:**

4...20mA 2 wire or 0...10V
Both analogue outputs are isolated.

Temperature output is also available in RTD (Pt100 3 wire) version.

- **Accuracy:**

RH% 1.8 between 10 and 90%
Temperature 0.5°C max.

- **Stability:**

Long-term drift < 0.5 RH%/year.

- **“Humi-Chip” environmental limits:**

-30...+90°C

- **Housing:**

IP66, for both wall, duct and remote sensor models.

- **Protection filter:**

Wire mesh/sintered stainless steel or teflon, protects against dust and other atmospheric contaminants.

- **Electrical connections:**

Terminal strip or 5 pole M12 connectors



Humi-chip[®] Module - Accurate, condensation

General description

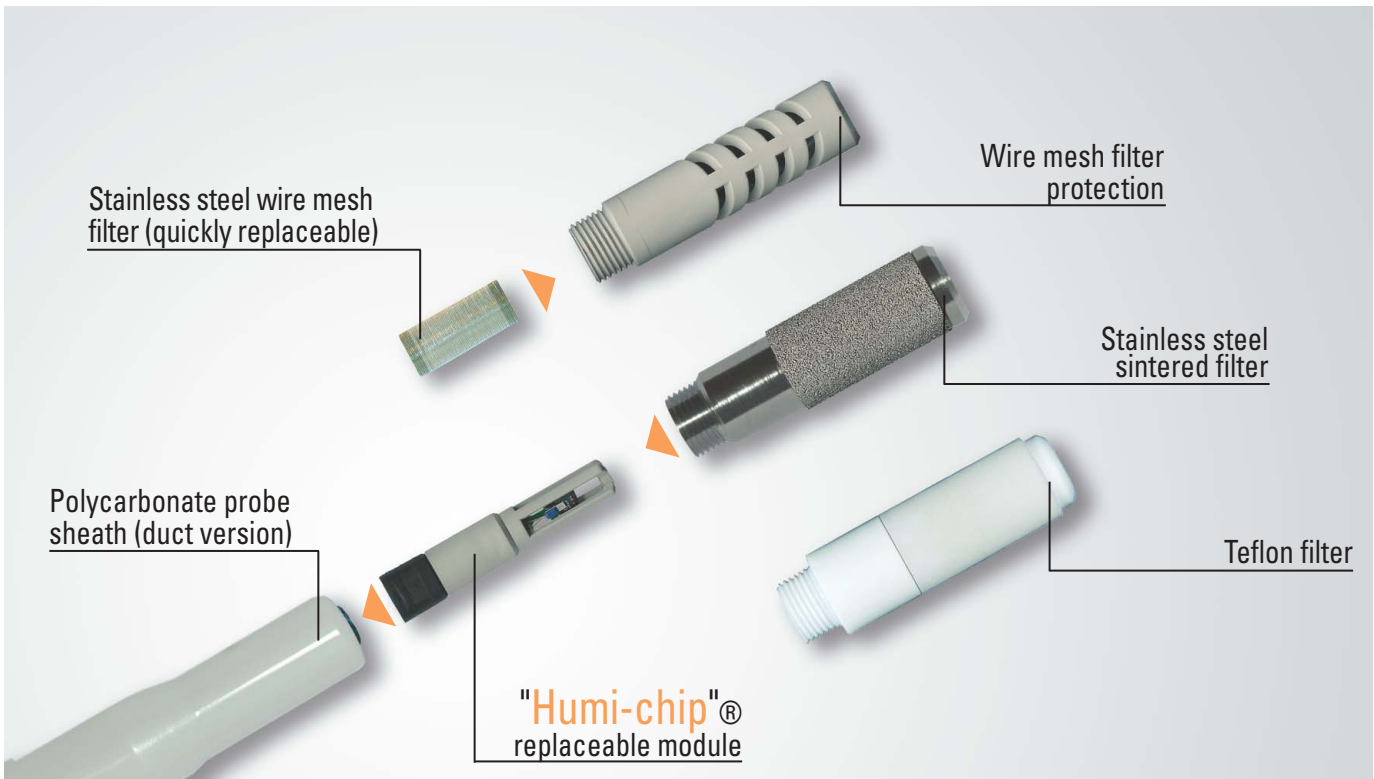

Characteristics at 25°C environmental temperature

1 st output Humidity	Range	0...100% RH	
	Output	4...20mA 2 wire; 500Ω max. or 0...10V; 500Ω min.	
	Accuracy (figure 2)	1.8% between 10... 90% RH Non-linearity, hysteresis and repeatability included	
	Working limits	see figure 1	
	Typical long-term drift	< 0.5 RH%/year	
2 nd output Temperature (option)	Available ranges	-30... +70°C (-22... 158°F)	
		-20... +30°C (-4... 86°F)	
		0... +50°C (32... 122°F)	
	Output	4... 20mA 2 wire; 500Ω max. or 0... 10V; 500Ω min.	
		Isolated vs. Humidity output	
Accuracy (figure 3)	Output 4... 20mA <0.5°C between -20... 80°C (-4... 176°F) Output 0... 10V <0.5°C between 0... 50°C (32... 122°F)		
RTD output - as alternative to mA or V output	(PT100 IEC 751) Tolerance: Class B (1/2 DIN) - 3 wire connection		
LCD display (option)	Digital display dimensions	10.5mm	
	Display range	0.0... 100.0% RH	
Power supply	4.20mA output	10... 30Vdc	Power consumption 2W max.
	0...10V output	18... 27Vac or 20... 30Vdc	
General characteristics	Housing material	Polycarbonate (colour: RAL 7038) Protection: IP66	
	Probe material	Polycarbonate - probe for duct mounting version	
	Safety	Compliance to EN 61010-1, double isolation, pollution class 2, installation class II	
	Electromagnetic compatibility	Compliance to CE standards EN 50081-2, EN 50082-2	
	Environmental temperature housing	-25... +70°C standard -20... +60°C with 2nd temperature output and/or display	
	Electrical connection	Spring terminal strip, AWG28-16 wire or 5 pole M12 threaded connector, AWG20 wires	
	Overall dimensions	see page 3	

Working limits of "Humi-chip" module

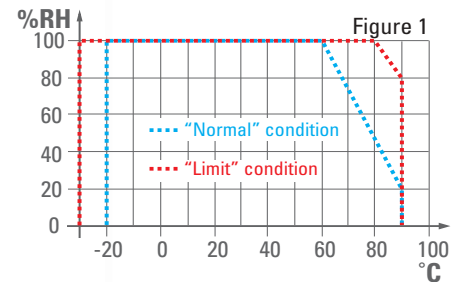

The measured reading tolerance is guaranteed through the "Normal" working conditions. A long-time period, at "Limit" conditions may generate a permanent drift up to +2 RH %.

Humidity Tolerance

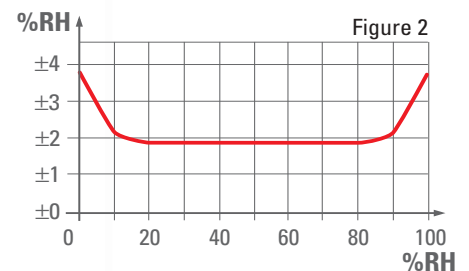

Temperature Tolerance

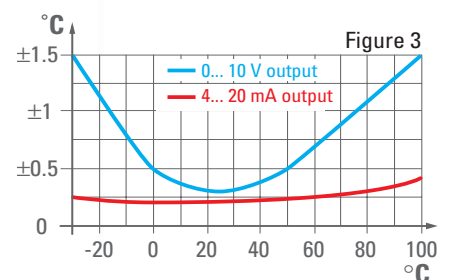

resistant, pre-calibrated and easily replaceable

Electrical wiring

4...20 mA models with 2 wire output

Version with internal removeable spring terminal strip

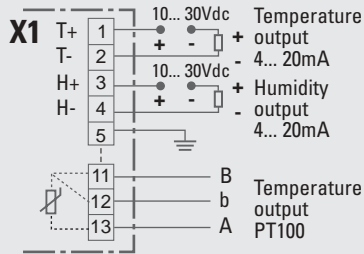

Version with 5 pole M12 connector

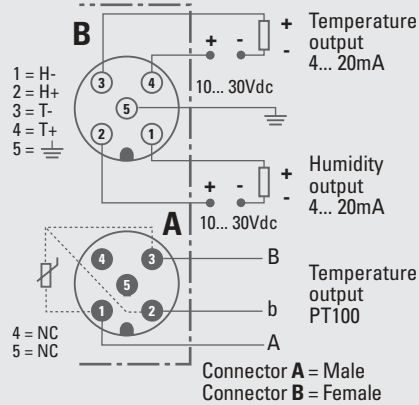

0...10V output models

Version with internal removeable spring terminal strip

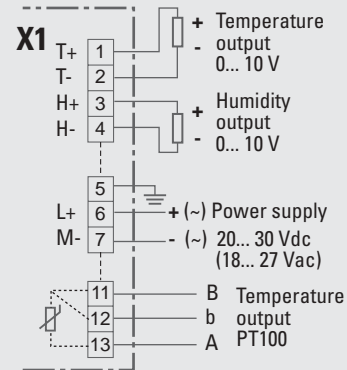

Version with 5 pole M12 connector

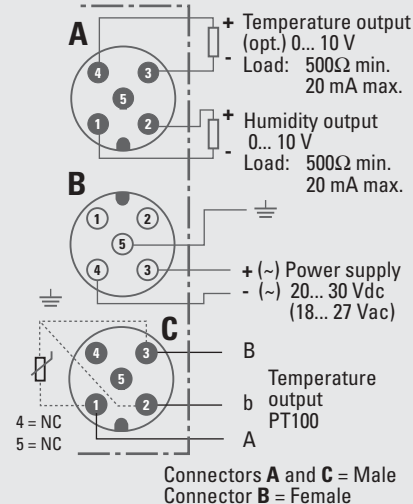

Dimensions

Mounting

Wall mounting

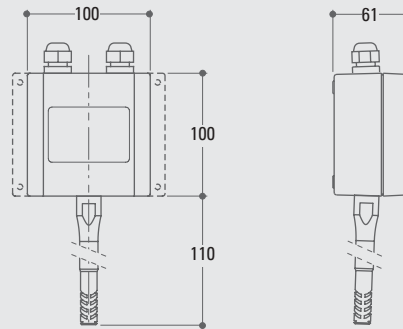

Duct mounting

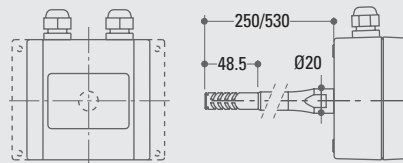

Remote sensor mounting

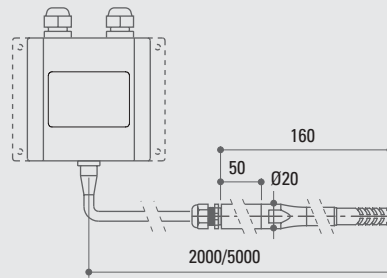

Output

Conduit M16



M12 Connector

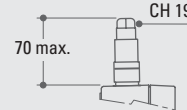

Mounting holes

Standard

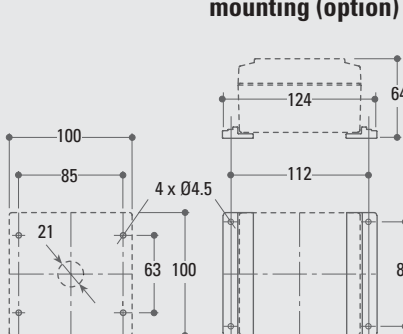

Brackets for wall mounting (option)

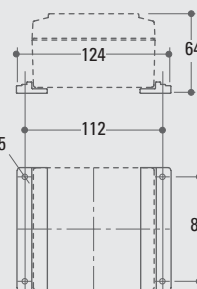

Applications

Storerooms to ripen and preserve fruit and vegetables ...



Storerooms for seasoning meat and cheese ...



Artificial snow making



Air conditioning and ventilation of industrial buildings (HVAC) ...



Commercial buildings, airports ...



Environmental conditions in libraries and museums ...



Data processing centers and computer laboratories ...



Green-house and incubator ...



Ordering codes

Model: **H1** - **A B C D** - **E F G** - **H I 0 0**

Mounting - Dimensions

Probe material

Filter

LCD Display (option)

Electrical connections

Temperature output (option)

Humidity output

Mounting	Dimensions	A	B
Wall	Ø20 x L110	P	0
Duct	Ø20 x L250	C	2
	Ø20 x L530	C	5
Remote	Ø20 x L160, cable 2m	R	2
	Ø20 x L160, cable 5m	R	5

Probe material	C
Polycarbonate	0

Filter	D
Stainless steel wire mesh	R
Sintered	S
Teflon	T

1 st output - Humidity	E
4... 20 mA (2 wire) / 0... 100% RH	1
0... 10 V / 0... 100% RH	2

2 nd output - Temperature (option)	F
Not fitted	0
4... 20 mA (2 wire) when 1st output = 4... 20 mA	1
0... 10 V when 1st output = 0... 10 V	2
PT100 - Compliance with IEC751	P

Temperature range	G
(if F = 0 or F = P)	0
-30... +70°C	1
-20... +30°C	2
0... 50°C	3
0... 100°C	4

Electrical connections	H
Terminals, with M16 conduit	M
2 connectors (M + F) M12, IP66	C

LCD Display (option)	I
Not fitted	0
Internal LCD Display	D

Ordering code example:

model **H1-C20R-111-MD00**

Humidity and temperature transmitter, duct mounting probe Ø20 x L250, stainless steel wire mesh.

Humidity output: 4... 20 mA/0... 100% RH.

Temperature output: 4... 20 mA. Range: -30... +70°C.

Terminal electrical connections and internal LCD display

Accessories and spares

"Humi-Chip"® module

Easy and fast replacement
(no calibration needed)



Ordering code:

Model: **AH-HUMICHIP**

Wire mesh stainless steel filter

with threaded filter protection

Porosity: 25 µm

Sampling time: 5 s (0...63%)

Suitable for clean environments; (no dust and moderate wind conditions)



Ordering code:

Model: **AH-FRI25**

Stainless steel sintered filter

with threaded connection

Porosity: 5 µm

Sampling time: 10 s (0...63%)

Suitable for dusty environments; not moisture resistant



Ordering code:

Model: **AH-FSI05**

Teflon filter

with threaded connection

Porosity: 10 µm

Sampling time: 120 s (0...63%)

Suitable for aggressive chemical environments, not suitable with high grade humidity

Ordering code:

Model: **AH-FT10**



Mounting brackets

for wall mounting

Material: epoxy painted aluminum (RAL 7038)

Distance between centers: 112 x 85 (page 3)



Ordering code:

Model: **AH-SFE2**

Wall mounting bracket for remote sensor

Plated steel bracket;

thickness 1 mm, depth 48 max.;

wall mounting 2 x Ø4 screws holes

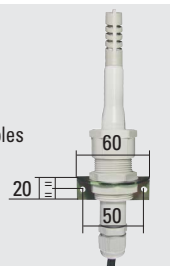

Ordering code:

Model: **AH-SMP01**

Adjustable flange Ø100 self-locking

anodized aluminum flange for Ø20 probe;

No. 4 holes Ø11; distance

between centers Ø75



Ordering code:

Model: **AH-FLA20**

ASCON spa
Via Falzarego, 9/11
20021 Baranzate
(Milano) Italy
Tel. +39 02 333 371
Fax +39 02 350 4243
www.ascon.it
sales@ascon.it

ASCON FRANCE

BP 76
77202 Marne Vallée -
Cedex 01
Tél. +33 (0) 1 64 30 62 62
Fax +33 (0) 1 64 30 84 98
www.ascon.fr
ascon.france@ascon.fr
AGENCE SUD-EST
Tél. +33 (0) 4 74 27 82 81
Fax +33 (0) 4 74 27 81 71

ASCON CORPORATION

1884 East Fabyan Parkway
Batavia, Illinois 60510
Tel. +1 630 482 2950
Fax +1 630 482 2956
www.asconcorp.com
info@asconcorp.com

WORLDWIDE NETWORK OF DIRECT SALES CENTRES, DISTRIBUTORS AND VARs

Europe

Belgium, Croatia, Czech Rep., Denmark, Estonia, Finland, France, Germany, Great Britain, Greece, Holland, Ireland, Norway, Poland, Portugal, Romania, Russia, Slovakia, Slovenia, Spain, Sweden, Switzerland, Turkey, Ukraine

Americas

Argentina, Brazil, Canada, Chile, Colombia, Ecuador, Paraguay, Peru, Uruguay, Venezuela

Rest of the world

Algeria, Australia, China, Egypt, Hong Kong, India, Indonesia, Iran, Israel, Malaysia, Morocco, New Zealand, Pakistan, Saudi Arabia, Singapore, Taiwan, Thailand, Tunisia, South Africa & South East Africa, UAE